

conversiontabel;
 1/16=1,5mm
 1/8=3mm
 1/4=6mm
 3/16=5mm
 1/32=0,8mm

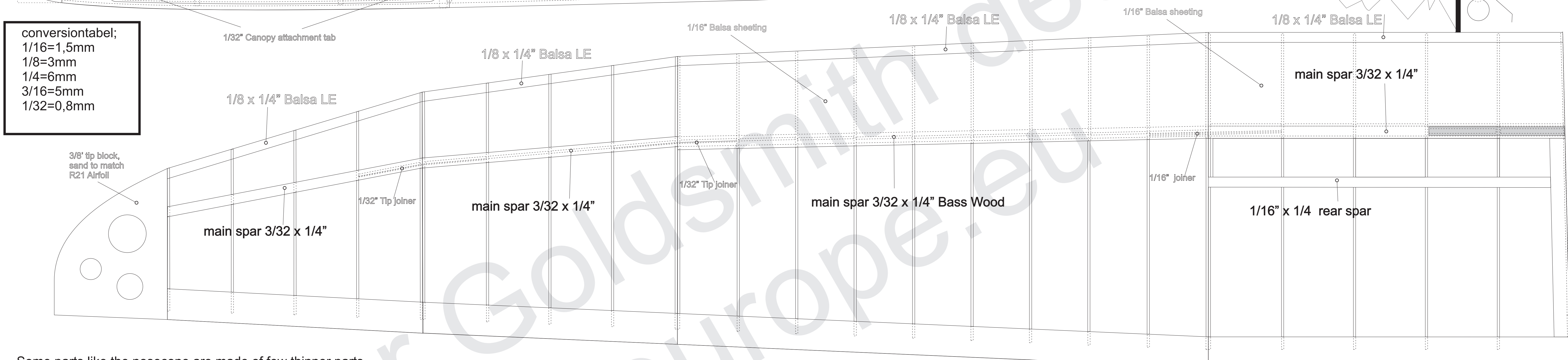

Some parts like the nosecone are made of few thinner parts and need to be glued together to reach right thickness.



Opal
 F3 - RES

Wingspan: 2m - 78.5"
 Length: 102.7cm - 40.5"
 Weight: 13-15oz 360- 425gms
 Airfoil: S8032
 Designed by: Peter Goldsmith
 Europe distribution: RC-Europe.eu